



AltRider Skid Plate for BMW R 1200 GSW INSTALLATION INSTRUCTIONS

The most up to date instructions can be downloaded from the product page at altrider.com, under the instructions tab.

Dear Rider,
Thank you for choosing AltRider! Whether a seasoned world adventurer or a first time ADV-Newbie, we welcome you to the AltRider experience. You can install your new product with the utmost confidence. AltRider designs, tests, and manufactures all of its products here in the United States. We are proud to do what we do, and honored to present to you the product of our labors.

Enjoy it, show it off, and most of all, RIDE IT!

Venture On,
Jeremy LeBreton

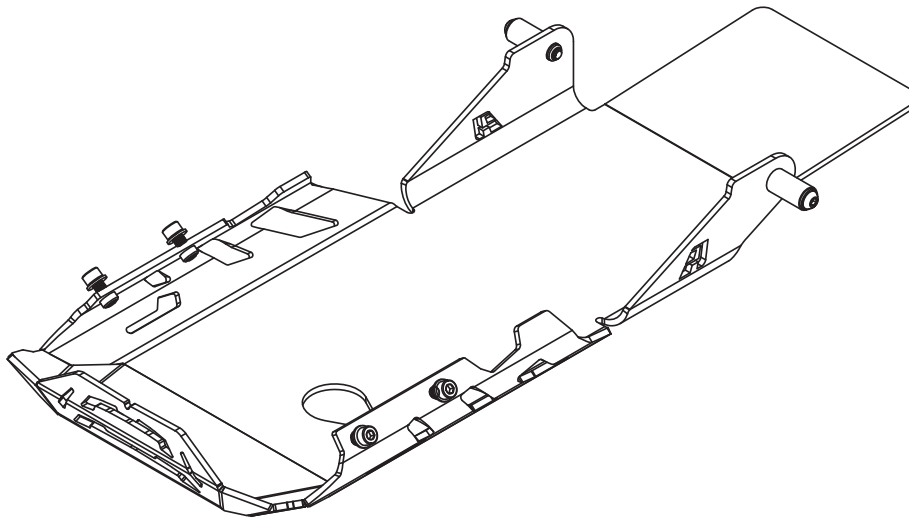

**AltRider Skid Plate for
BMW R 1200 GSW**

Package Contents:
- Skid Plate
- Hardware Kit
- Instructions

AltRider LLC

Global

mailing: 4000 Aurora Ave N Ste 100
Seattle, WA 98103 USA
phone: 206-922-3618
email: info@altrider.com
web: www.altrider.com

Europe

mailing: AltRider EU
Heliumstraat 230
2718 RS Zoetermeer
The Netherlands

email: info@altrider.eu

**R116 REV1
MADE IN THE USA**



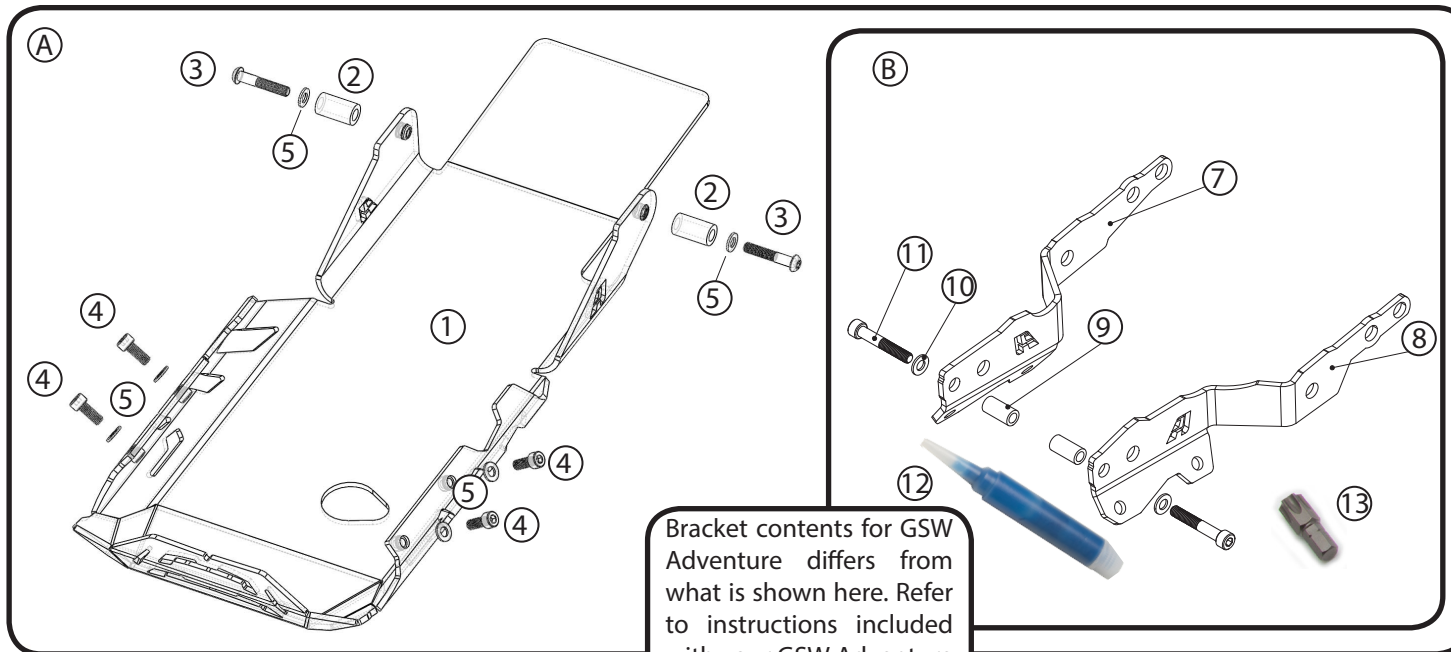

Bracket contents for GSW Adventure differs from what is shown here. Refer to instructions included with your GSW Adventure brackets (R113-9-1200).

Kit:

- (A) Skid Plate Contents**
- (1) Skid plate
 - (2) (2) Center stand pins
 - (3) (2) M8 x 45mm button head bolt
 - (4) (4) M8 x 14 mm SH cap bolts
 - (5) (6) M8 washers

(B) Bracket Contents

- (7) Right bracket
- (8) Left bracket
- (9) (2) Spacers
- (10) (2) M8 washers
- (11) (2) M8 x 50 SH cap bolts
- (12) Thread locker
- (13) T50 torx driver

Recommended tools:

- (1) hardware tray
- (2) 1/4" ratchet
- (3) 1/4" driver
- (4) 1/2" driver
- (5) 1/2" extension
- (6) M5 allen
- (7) M6 allen
- (8) Snap ring pliers
- (9) 13mm wrench & socket
- (10) 8mm socket
- (11) Thread locker

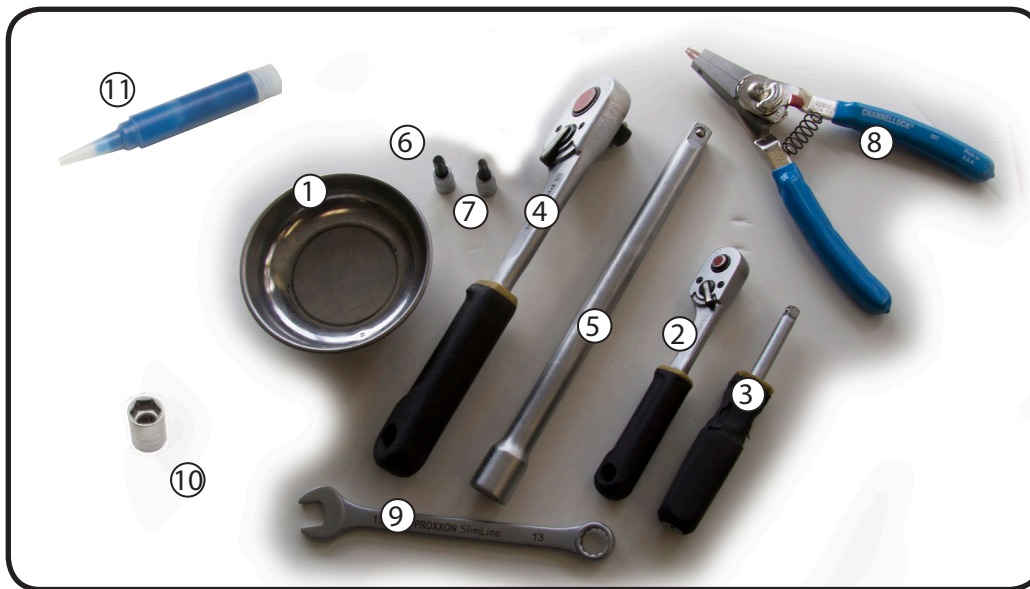

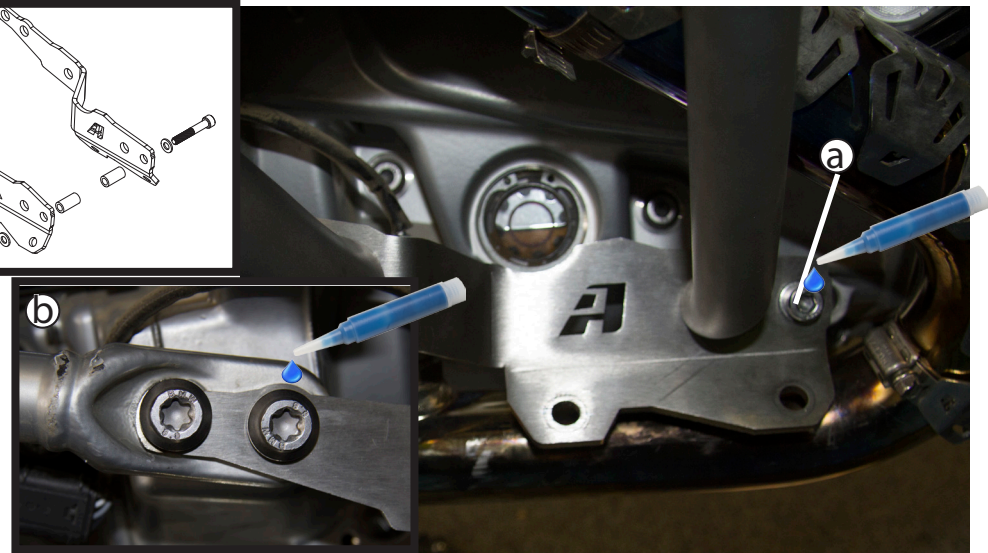
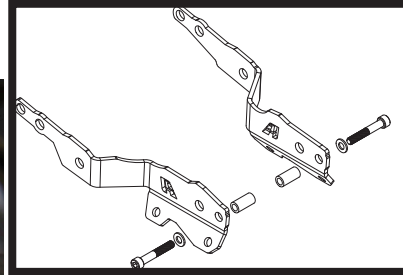

① NOTE: If you also purchased AltRider crash bars install them first, reference crash bar instructions and take note that **step #1 is critical**. If you already have AltRider crash bars installed skip to step #3. Place bike on center stand. Remove OEM skid plate and any brackets. Using a T50 Torx driver remove the (2) OEM engine bolts from each side, keep them.

② (IF YOU ARE INSTALLING SKID PLATE ON ADVENTURE MODEL, REFER TO SPECIAL INSTRUCTIONS INCLUDED WITH ADVENTURE BRACKETS) Starting with the right side install the brackets with spacer, M8 bolt and washer (a), and (2) OEM M10 Torx bolts (b). Use anti-seize. Get all fasteners started but do not tighten yet. Repeat on the left side. See diagram above for reference. TIP: take your time getting the frame aligned with holes in engine mounts. Note: If the holes are not aligned have a helper try lifting the rear of the bike slightly to help.



③ Place the bike on its side stand. Using your hand compress the rear brake caliper so you can freely move the rear brake lever down.

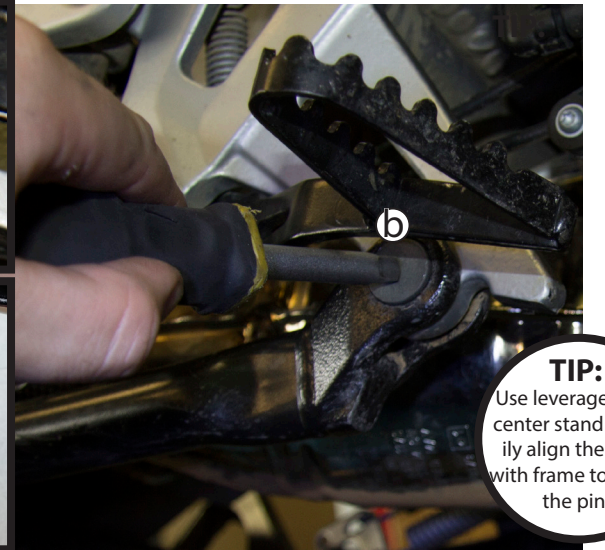

TIP:
Use leverage of the center stand to easily align the stand with frame to accept the pins.

④ One side at a time and starting on the right side, remove the snap ring (a). Push OEM pin inward a bit with extension to get it started (b). Lube the AltRider aluminum hollow pin with grease, and use it to push the OEM pin out the rest of the way (c). Push AltRider pin completely into place. Repeat for left side.

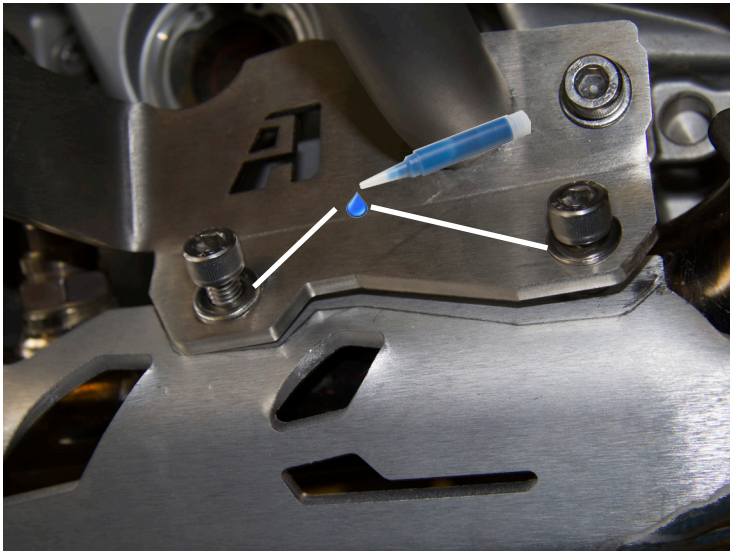

TIP: It is suggested that you prop the skid plate up against bike with a box or your foot if a helper is not available.

- ⑤ Align the front of the skid plate with the front brackets and using an M6 driver install all (4) M8 socket head cap bolts and M8 washers. Use thread locker. Leave all (4) loose for now.



- ⑦ With bike still on side stand. Apply loctite to each M8 x 45mm long Button Head bolt. Install bolt with washer through each hollow center stand pin and into the threaded insert in the skid plate. Tighten each M8 bolt to 10nm of torque.



- ⑥ Adjust pins so they are centered on the frame, with a few millimeters protruding from both the inner and outer side of the center stand pivot.



- ⑧ Check brake pedal action for clearance to bolt head. Push pin in further or adjust lever if more clearance is needed.

Return to bracket bolts listed in step #2 and torque the M8's to 13nm and the M10's to 55nm. Tighten all (4) front mount M8 bolts (from step #5) to 13 nm of torque. Ride for 100 - 500 miles and check inspect all fasteners for correct torque rating.

CONGRATULATIONS!

You've completed your installation. If at any point you have questions about your installation or have any feed back for us, we'd love to hear it. A downloadable version of these instructions can be found at our web site. www.AltRider.com

After 5 hours of riding, or 100 miles, check all the fasteners on the assembly to ensure they are tightened to spec.

Global Office:

email: info@AltRider.com
phone: +1 206-922-3618
address: 4000 Aurora Ave N
Ste 100
Seattle, WA 98103

Europe Office:

email: info@AltRider.eu
address: AltRider EU
Heliumstraat 230
2718 RS Zoetermeer
The Netherlands

TERMS OF USE, WARRANTY AND LIABILITY WAIVER

AltRider LLC, a Washington company, having its principal place of business in Seattle, WA ("AltRider") offers its motorcycle accessories (the "Product") with the terms, conditions and notices as follows:

Terms of Use

This Product is offered to you conditioned upon your acceptance without modification of the terms, conditions, and notices contained herein. Installation and/or use of this product implies acceptance of all such terms, conditions, and notices. If you do not agree to these terms, do not buy the Product. If you have already bought the Product and do not agree to these terms, return this Product promptly including the packaging and all written materials, to AltRider.

Limitation of Liability and Warranty Disclaimer

You may return your merchandise for a full refund or exchange, less any original or return shipping fees under these conditions:

1. Only if the merchandise is in 100% factory condition. Original manufacturer's packaging and same condition as sold – original boxes, packaging material, instructions, documentation, parts, and attached tags.
2. Only unused, unscratched, uninstalled, undamaged merchandise will be accepted. Do not install equipment until you are sure you want to keep it. Package items carefully in protective materials before returning them. Never ship an item in its original manufacturers packaging – it will arrive damaged. Please use a postal box or other adequate packaging to ensure your return or exchange is not damaged on the way back to AltRider.com.

To read more about our exchanges and returns policy, on the web, navigate to <http://www.altrider.com/info/exchangesAndReturns>

Excepting the warranties stated in the preceding paragraph, AltRider hereby disclaims all other warranties and conditions with regard to the Product including all implied warranties and conditions of merchantability and fitness for a particular purpose. There are no warranties which extend beyond the description on the face hereof. AltRider does not warrant against damages or defects arising out of use or installation of the Product. Installation instructions are provided for your convenience. AltRider is not responsible for any damages arising out of the installation, improper or otherwise, of the Product. No warranty of any kind, expressed or implied, is made regarding the safety of this Product.

To the extent allowed by law, AltRider shall not be held liable for any direct, indirect, punitive, incidental, special or consequential damages arising out of, or connected with, the use or misuse of this Product. Buyer assumes all risks and liability arising from use of this Product.

Entire Agreement

This document states the entire obligation of AltRider with respect to the Product. If any part of this agreement is determined to be void, invalid, unenforceable or illegal, including, but not limited to the warranty disclaimers and liability limitations set forth above, then the remainder of the agreement shall remain in full force and effect.

Applicable Law

This agreement is governed by the laws of Washington, USA. You hereby consent to the exclusive jurisdiction and venue of the courts of Washington, USA, in all disputes arising out of or relating to the use of this product.

